

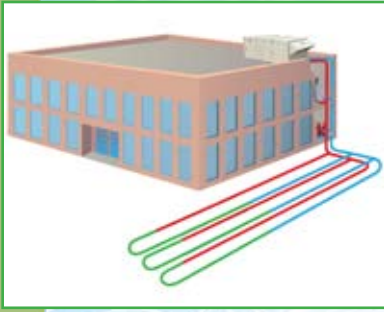

Geothermal & Water-Source Heat Pump

SOLUTIONS

Geothermal Water Heat Exchanger Systems



Closed Loop Horizontal Well System

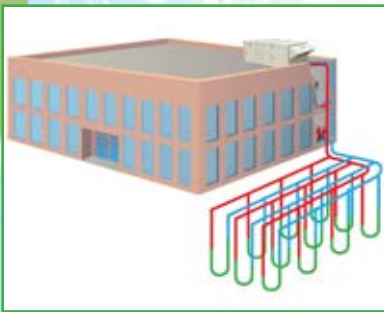

Closed Loop Vertical Well System

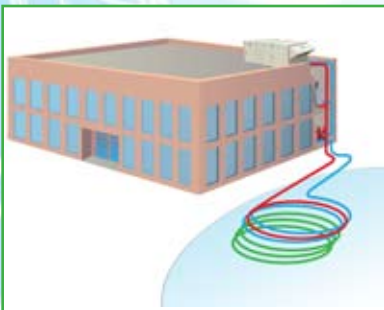

Closed Loop Surface Water System



Open Loop Groundwater Well System

Heat Pumps

Heat pumps can provide energy efficient cooling and heating using the unit's refrigeration circuit. Reversing the flow of the unit's refrigeration circuit allows the indoor coil to be used as a heating coil. This is a more efficient method of heating than electric resistance heating because a heat pump can reject more heat to the space per the amount of energy used. Thus, the operating costs of heat pump

heating are always less than the operating costs of electric resistance heating. Heat pump heating is also a more efficient method of heating than gas heating and, depending on the cost of electricity and natural gas or propane, heat pump heating can have less operating costs than gas heating. AAON heat pumps are available as air-source, water-source, and geothermal.

Geothermal Heat Pumps Systems

Geothermal heat pump systems take advantage of the earth's relatively constant temperature and use the ground or surface water to reject or absorb heat. Geothermal heat pumps offer better energy efficiency than air-source or water-source heat pumps. This is because air-source units operate at generally colder air temperatures in the winter and warmer air temperatures in the summer than the earth's temperature, resulting in less effective heat transfer. Water-source units require additional water cooling, i.e. a cooling tower, and water heating, i.e. a boiler, to maintain the desired water loop temperature, while geothermal heat pumps operate at the relatively constant subterranean temperature.

During the heating season, geothermal heat pumps efficiently absorb heat from the earth and provide this heat to the building. During the cooling season, geothermal heat pumps absorb

heat from the building and store the heat in the earth to be used during the heating season.

Geothermal heat pump system advantages include energy efficient operation at extreme ambient conditions, no requirement of back up electric or gas heat, no requirement of the use of a cooling tower or boiler in the water system, and the possibility of a balance of heating and cooling occurring.

In a properly designed, ground-couple system, operating and maintenance costs are low because a cooling tower and boiler are not required in the system. The pipes that make up the ground heat exchanger can be oriented in a vertical, horizontal or spiral pattern. Any of these patterns can be designed to provide the same fluid temperatures under a given set of conditions. The choice depends on available land, soil conditions, and excavation costs.

Benefits of Geothermal Heat Pumps

- Heat recovery offers energy savings
- Performs both heating and cooling
- Operating cost savings in any climate
- Tax incentives and power company rebates
- Energy use and peak demand reduction
- Environmentally friendly
- Low maintenance
- Quiet operation

AAON Advantages

High Efficiency - Brazed Plate, Shell and Tube, and Coaxial Heat Exchangers, Direct Drive Backward Curved Plenum Fans, Double Wall High Performance Composite Panel Construction, 10-100% Variable Capacity Scroll Compressors

Flexibility - Factory Installed Energy Recovery Wheels, High Efficiency Filtration, Modulating Humidity Control, Make Up Air Capability, R-410A Scroll Compressors, Waterside and Airside Economizers, VFD Controlled Supply, Return, and Exhaust Fans, Factory installed controls options

Serviceability - Hinged Access Doors, Water Piping and Heat Exchanger Access, Color Coded Wiring

Solutions - Replacement or New Construction, LEED Points, Power Company Rebates, Tax Incentives

Water-Source Heat Pump Systems

Water-source heat pumps can run in either heating or cooling mode when the water temperature is maintained within a given operating range. During cooling season, when most the heat pumps are operating in cooling mode, heat removed from the air is transferred to the water loop. This causes the temperature of the water in the loop to rise, making it necessary to remove heat from the water. A cooling tower or evaporative water cooler rejects this heat to the outdoor air.

During heating season, when most of the heat pumps are operating in heating mode, heat is removed from the water loop and transferred to the air. This causes the temperature of the water in the loop to

drop, making it necessary to add heat to the water loop. A boiler or water heater adds heat to the loop maintaining the loop temperature above the minimum design temperature.

During mild weather, some heat pumps will operate in cooling mode while other heat pumps will operate in heating mode. Heat rejected by the units operating in cooling mode can be used by the units operating in heating mode. If the loop water temperature remains between the upper and lower operating temperature, neither the boiler nor the cooling tower need to operate. In this manner, a water-source heat pump system provides a form of heat recovery and an opportunity to save energy.

To find out more information about geothermal and water-source AAON equipment contact your local AAON sales representative.

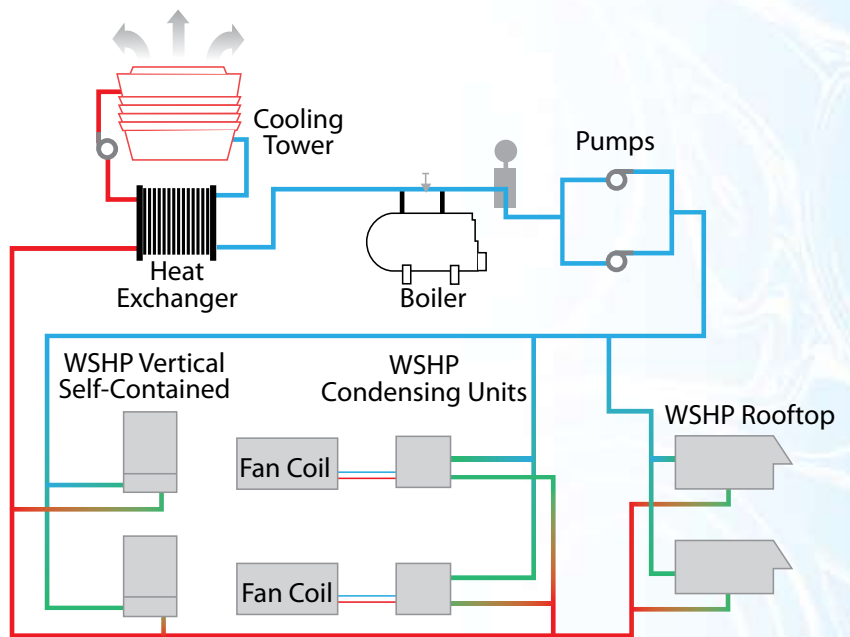

Closed Loop Water Source Heat Pump System
(Cooling Mode)

AAON Environmentally Friendly HVAC Product Family

Customer Commitment – AAON encourages environmentally responsible design by incorporating many energy saving features into our superior heating and cooling products. In addition to energy efficiency, AAON also offers environmentally friendly R-410A refrigerant capability in all our cooling and heat pump equipment. As countries throughout the world phase out CFC and HCFC refrigerants, R-410A is becoming the global standard and AAON is leading the way!



Rooftop Units



Condensers and Condensing Units



Air-Cooled or Evaporative-Cooled Chiller



*** Units can be installed in geothermal or water-source heat pump applications.**

Outdoor Air Handling Units



Indoor Air Handling Units



Self Contained



Boiler



Custom Indoor or Outdoor Air Handling Units



1,500 - 200,000+ CFM AHU
 • Cooling Only
 • Direct Fired
 • Indirect Fired



Defining Quality. Building Comfort.

It is the intent of AAON to provide accurate and current product information. However, in the interest of product improvement, AAON reserves the right to change pricing, specifications, and/or design of its product without notice, obligation, or liability.

Copyright © AAON, all rights reserved throughout the world.
 AAON® and AAONAIRE® are registered trademarks of AAON, Inc., Tulsa, OK.